

Exhibit 6 – Test Report
IRIDIUM SUBSCRIBER UNIT (ISU) - MOBILE

FCC ID: IHDT6NJ1

Model No. 9522 (Sebring)

Equipment Applicant: **Motorola, Inc.**
600 North U.S. Highway 45
Libertyville, IL 60048

Tests Conducted By: **General Dynamics Decision Systems**
EMC Test Facility
8201 E. McDowell Rd.
Scottsdale, Arizona 85252

Tests Date: **March 18th – 26th, 2002**

Test Summary: **Complies with FCC Part 25, Satellite Communications**

The General Dynamics Decision Systems
EMC Laboratory is accredited through the



NVLAP Lab Code 100405-0

This document shall not be reproduced,
except in full, without the written approval
of the laboratory. This document shall not
be used by the client to claim product
endorsement by NVLAP or any agency
of the U.S. Government.

6.0 Introduction

6.0.1 Product Description

The IRIDIUM® Subscriber Unit (ISU) can take several different forms of a Mobile Earth Station (MES) for the IRIDIUM® System. Two of these are the Portable, or Handheld, Subscriber Unit (Model No. 9505) and the Mobile Subscriber Unit (Model No. 9522). This test report is for the Mobile unit, 9522, which is also known as the Sebring.

These satellite phones consist of an L-Band Transceiver (LBT) capable of simultaneous transmit and receive (duplex) operation covering the frequency range of 1616 MHz to 1626.5 MHz. The frequency accesses used for duplex channels are organized into sub-bands each of which contains eight frequency accesses. Each sub-band, therefore, occupies 333.33 kHz (i.e. 8 x 41.667 kHz). Up to 30 sub-bands containing 240 frequency accesses may be used for duplex channels.

6.0.2 Facility Description

All testing reported herein was performed at the General Dynamics Decision Systems (GDDS) EMI/TEMPEST Test Facility, located in Scottsdale, AZ.

GDDS EMC Test Facility Address:

GENERAL DYNAMICS
Decision Systems

Hayden EMC Facility, M/D H2550
8201 E. McDowell Rd.
Scottsdale, AZ 85252-1417

The test facility includes a certified three-meter and ten-meter Open Area Test Site (OATS) and several shielded enclosures. The facility has been found to be in compliance with the requirements of Section 2.948 of the FCC rules, per Registration Number 90811, dated October 1, 2001. The facility has also been issued a Certificate of Accreditation through the National Voluntary Laboratory Accreditation Program (NVLAP) by NIST. This is under NVLAP Code: 100405-0 and is effective through September 30, 2002. The facility is in compliance with all CISPR 16 requirements.

6.0.3 Quality System

The EMI/TEMPEST Test Laboratory maintains a Quality Manual that describes the quality assurance program of the EMC/TEMPEST Facility to set forth procedures covering all quality assurance functions. This manual has been constructed to reflect a quality program in compliance with the requirements of the following:

- National Institute of Standards & Technology (NIST) National Voluntary Laboratory Accreditation Program (NVLAP)
- NIST/NVLAP EMC MIL-STD 462 Program Handbook (Apr. 1994)
- NVLAP EMC and Telecommunications FCC Methods Handbook 150-11 (Apr. 1995)
- MIL-Q-9858A, MIL-STD 461, 462, 463, 461D, 462D
- National Security Agency Technical and Security Requirements Document for the Endorsed TEMPEST Test Services Program, NSA TSRD No. 88-8B, 5 Oct. 1993

6.0.4 Standard References

- | | |
|------------|--|
| 47 CFR 2 | Code of Federal Regulations, Title 47, Part 2, "Frequency Allocations and Radio Treaty Matters; General Rules and Regulations" |
| 47 CFR 25 | Code of Federal Regulations, Title 47, Part 25, "Satellite Communications" Subpart C, "Technical Standards" |
| C63.4-1992 | American National Standards Institute (ANSI), "Methods of Measurement of Radio-Noise Emissions from Low-Voltage Electrical and Electronic Equipment in the Range of 9 kHz to 40 GHz" |

6.1 Test Procedures

6.1.1 Requirements

The Sebring is subject to FCC Part 25, Subpart C and Part 2 for FCC Certification for units marketed within the United States. The following tests, as specified in FCC Part 2, with limits as defined in FCC Part 25, and shown in Table 6.1-1 below were performed on the Mobile Iridium Subscriber Unit (ISU).

Table 6.1-1 Tests Required for Certification of the Sebring

Test Parameter	FCC Part 2 Paragraph Number	FCC Part 25 Paragraph Number	FCC Part 25 Limit
Spectrum Mask	-	25.202	<u>Frequency Offset</u> 20.833-41.667 kHz <u>Atten.</u> 25 dBc 41.667-104.16 kHz 35 dBc > 104.67 kHz 43+10log(Pt)
Spurious Emissions Antenna Terminals	2.1051	25.202 25.213	Same as above
Radiated Spurious Emissions	2.1053	“	“
Carrier Frequency Stability – Temperature	2.1055	25.202	0.001%
Carrier Frequency Stability – Voltage	2.1055	25.202	0.001%

6.1.2 Operational Configuration

The ISU was operated in transmit mode at maximum rated output power. The unit was configured for operation at three (3) different ‘traffic channels’, i.e. low, mid, and high. These settings were accomplished through direct Key Pad Programming (KPP) with the unit in “Test Mode”. An auxiliary handset and DSC breakout board were used to control the Sebring operation.

<u>Ancillary Equipment</u>	<u>Item Number</u>
Handset	SCN4052A
Handset Cradle	SYN7908B
DSC Breakout Board	01P58183H Rev A

A special test Subscriber Identity Module (SIM) was required for KPP operation. The Test Mode is accessed by suspending the phone, i.e. depressing and holding the “#” key for approximately 3 seconds. The Static Traffic Channel command, “29xyyzabc#”, was used to select the appropriate channel and maximum power output level. The transmitter was modulated with typical DEQPSK modulation using pseudo-random data. General test setups are shown as Figures 6.1-1 and 6.1-2.

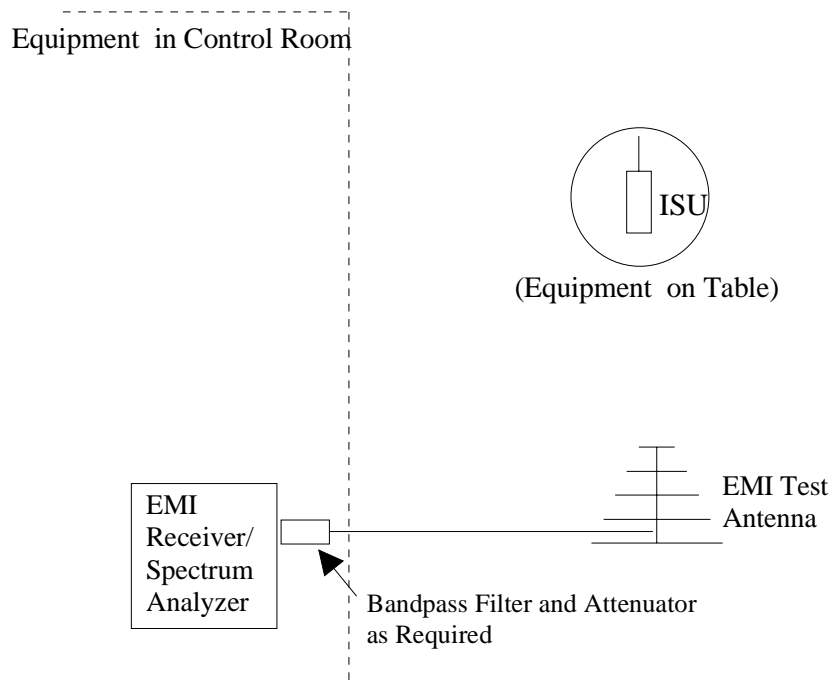

Figure 6.1-1 General Radiated Test Setup for Tests

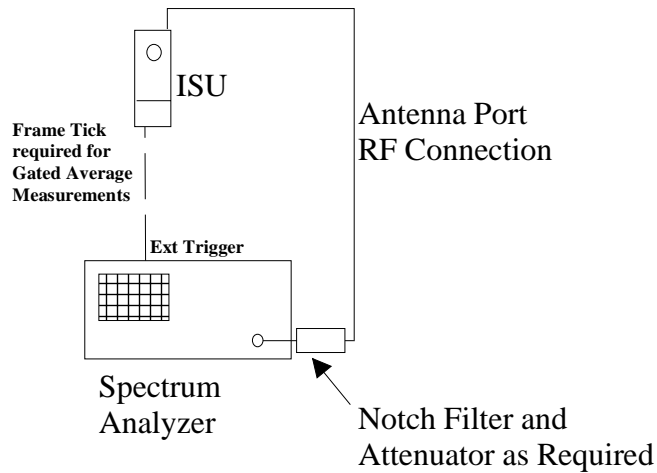

Figure 6.1-2 General Conducted Test Setup for Tests

6.1.3 Measurement Equipment

Test Equipment Nomenclature	Item Number	Manufacturer	Model Number	Cal. Date	Cal. Due
Biconilog Antenna	T47085	EMCO	3142B	01/07/02	01/31/03
Biconilog Antenna	T47086	EMCO	3142B	01/07/02	01/31/03
Horn Antenna	G43961	EMCO	3115	07/02/01	06/30/02
Antenna Mast	0003-2246	EMCO	2070-2	NCR	NCR
Antenna Controller	G72315	EMCO	2090	NCR	NCR
Spectrum Analyzer/ EMI Receiver	G68094	Rhode & Schwarz	ESI40	05/17/01	05/31/02
Spectrum Analyzer/ EMI Receiver	G71179	Rhode & Schwarz	ESI-7	10/25/01	10/31/02
Attenuator, 20 dB	T48784	HP	8491	05/16/01	05/31/02
Attenuator, 30 dB	T14267	Narda	766-30	05/16/01	05/31/02

6.1.4 Radiated Spurious Emissions Procedure

Radiated spurious emissions were measured over the frequency range of 30 MHz to 16.3 GHz in an anechoic chamber (20ft x 24ft x 16ft) and an open area test site (OATS). Refer to Figure 6.1-2 and 6.1-3 for test setups.

The radiated emissions between 30 MHz and 1 GHz were initially measured in a semi-anechoic shield room in order to identify the emissions in an ambient free environment before proceeding to the open area test site (OATS). This provides the capability of taking accurate measurements in a higher ambient environment such as at the rooftop OATS. The Rohde & Schwarz EMI Receiver System was used for the pre-scans. Typically, signals within approximately 10 dB of the limit are noted for measurements on the OATS.

Final measurements on the OATS were taken with a Rohde & Schwarz EMI Receiver System receiver system at a 3-meter test distance from the receiving antenna. The Sebring was placed on a .8-meter high non-conductive table on a rotating turntable that is flush with the site ground plane. The receiving antenna was scanned over a height range from 1 to 4 meters in both antenna polarities, and the turntable was rotated 360 degrees. The highest emissions were recorded and the final field strength level determined using the following formula:

$$\text{Field Strength (dBuV/m)} = \text{Measured Level (dBuV)} + \text{Cable Loss (dB)} + \text{Antenna Factor (dB)}$$

The radiated emissions between above 1 GHz were measured in an anechoic chamber using a EMCO 3115 Horn antenna at a 3-meter distance. The emissions were maximized by rotating the equipment on the turntable and by changing polarities of the antenna.

The test methods of ANSI 63.4 were used for performing the Radiated Emissions tests.

6.1.5 Conducted Spurious Emission, 30 MHz to 16.3 GHz, Procedure

Conducted spurious emissions are the radio frequency voltages or power generated within the equipment and appearing at the equipment's output terminal when properly loaded into its characteristic non-radiating artificial load. The mean power of the conducted spurious and harmonic emissions shall be attenuated below the mean output power of the transmitter by:

<u>Frequency Offset</u>	<u>Attenuation (per 4 kHz)</u>
20.833 to 41.667 kHz	25 dBc
41.667 to 104.16 kHz	35 dBc
>104.16 kHz	51.45 dBc

In the range of the frequencies between 1559 to 1605 MHz, emissions shall not exceed an EIRP density level of -70 dBW/MHz (-40 dBm/MHz) averaged over any 20 ms period and -80 dBW (-50 dBm) for any discrete (BW<600 Hz) spurious emissions. EIRP measurements were performed using a maximum worst-case antenna gain of 3 dBi included in the offset of the measurement system along with other measurement system losses.

The spectrum was scanned from 30 MHz to the tenth harmonic of the carrier. The level of the carrier and the various conducted spurious and harmonic emissions were measured by means of a calibrated receiver system. All signals were measured with peak detection (worst case) except at frequencies between 50% to 250% of the carrier and the 1559 to 1605 MHz band where average measurements were taken using an external frame trigger from the unit under test.

6.1.6 Frequency Stability Procedure

The carrier frequency stability is the ability of the transmitter to maintain an assigned carrier frequency. The minimum frequency stability shall be +/- 0.001 % (10 ppm) at anytime during normal operation. Frequency measurements were made at the extremes of the temperature range -30 to +55 degrees C and at intervals of not more than 10 degrees throughout the range. A period of time sufficient to stabilize all of the components in the equipment shall be allowed prior to each frequency measurement. The frequency stability of the transmitting equipment shall be checked with variations in:

- a) Temperature -30 to +55 °C
- b) Supply Voltage over the specified DC voltage range

The carrier frequency of the transmitter was measured at room temperature to provide a reference. Measurements were started at -30 °C and subsequently made at each 10 degree intervals until +55 °C was reached. A period of not less than 35 minutes was allowed between temperature soaks to allow stabilization of the equipment between successive measurement intervals.

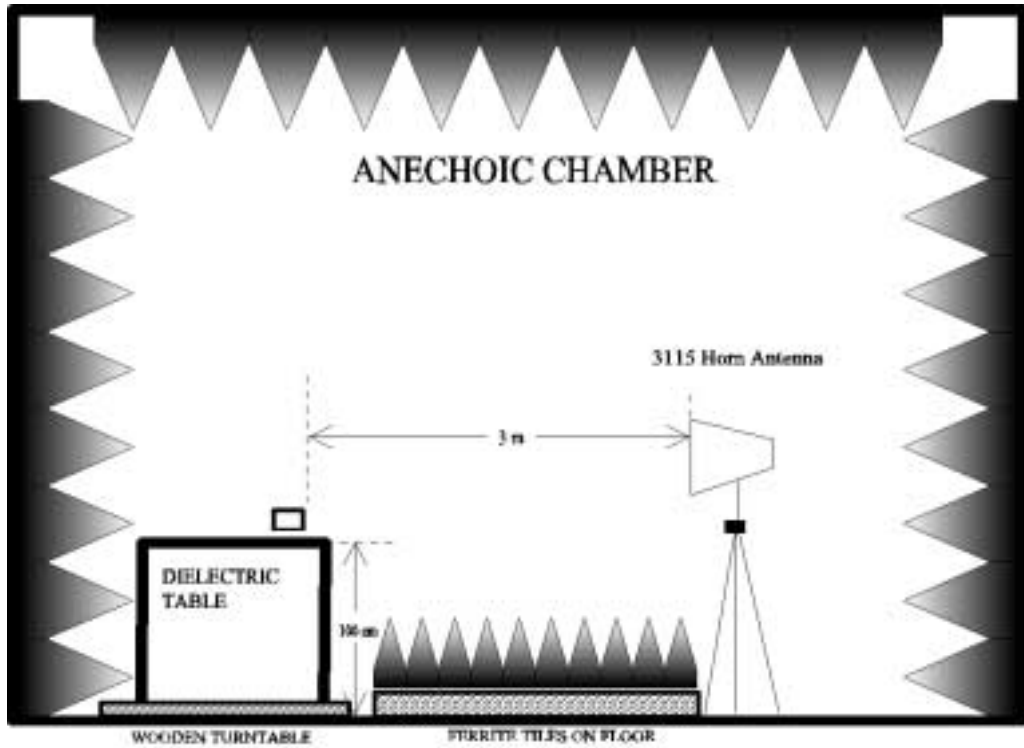

Figure 6.1-2 Radiated Spurious Emissions Test Setup - Chamber

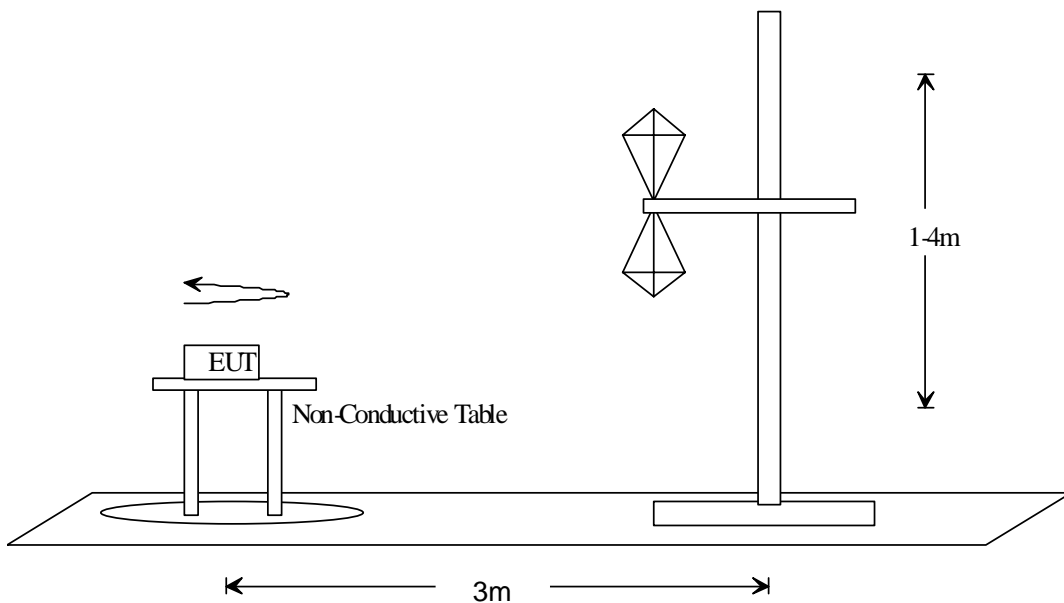

Figure 6.1-3 Radiated Spurious Emissions Test Setup -OATS

6.2 Test Results

6.2.1 RF Power Output Data

The RF power output was measured with the indicated voltage and current applied into the final RF amplifying device(s). The RF output, DC current and RF Input Power are all time-averaged values which reflect a 9.2% (8.28 ms Tx bursts/90 ms frame) transmit duty cycle characteristic of transceiver operation.

- RF Output Power: .588 W
- DC Voltage: 7.5V
- DC Current: 0.404 Amps
- RF Input: 0.092 mW

Since the transceiver is intended for use with specific antennas (with a worst-case 3 dBi gain over isotropic and “non-standard” RF connector), EIRP is measured. The antenna substitution method was used. The results indicated is the maximum EIRP found over the channels and transceiver orientations tested. The measured value reported below again takes into account the transmit duty cycle of 9.2%.

Maximum EIRP: +30.7 dBm (1.2W)

6.2.2 Radiated Spurious Emissions Measurement Test Results

All measurements were made with the Sebring transmitting at its maximum rated output power. Most of the measured signals displayed significant margin, >20 dB, as compared to the appropriate limits. All of the measured signals were below the required limits. For this reason, it was only necessary to re-measure a few of these signals using the specified Quasi-Peak or Average detectors.

The measured signals are shown in the graphs of Appendix A.

6.2.3 Conducted Spurious Emissions Measurement Test Results

The conducted spurious emissions were measured on the Sebring and were all below the required limits. The graphs in Appendix B illustrate the final measurement results.

6.2.4 Frequency Stability Measurement Test Results

The carrier frequency met its 0.001% stability requirements for both voltage and temperature variations. The results are shown in Appendix C.

Appendix A

Radiated Spurious Emission Measurements

30 MHz to 16.3 GHz

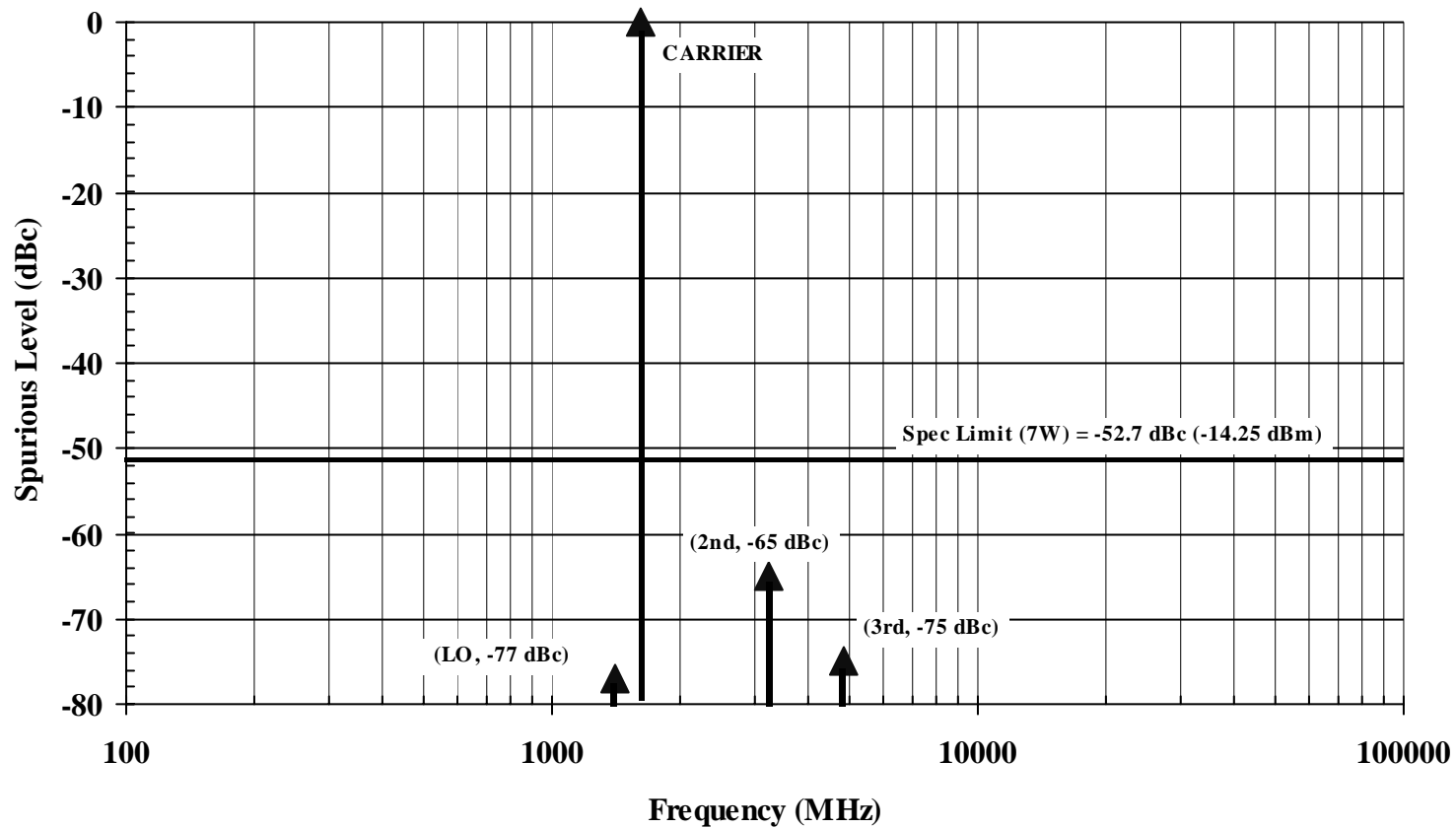

TRANSMITTER RADIATED EMISSIONS, MAX LEVELS OF CHANNELS #3, 120, 238

Carrier Power: 7 W max (+38.45 dBm), .645 W average (+28 dBm)
 Carrier Frequency: 1616 to 1626.5 MHz (240 Channels)
 Channels Tested: Channels #3, #120, and #238 (worst case emission presented)
 *All other emissions greater than 20 dB below the spec were not reported
 *Spectrum search performed from 30 MHz to 16.3 GHz (10X Carrier Frequency)

GDDS EMC Group
 3/29/02

Appendix B

Spectrum Mask

and

Conducted Spurious Emission Measurements

30 MHz to 16.3 GHz

BANDWIDTH MEASUREMENT DATA
FOR TRANSMITTER TYPES Q7W

DEVIATION OF THE CARRIER WITH QPSK MODULATION

HORIZONTAL SCALE = 1 MHz/DIVISION

VERTICAL SCALE = 10 dB/DIVISION

RESOLUTION BANDWIDTH = 3 kHz

POWER LEVEL = .6 W (Mean Output Power)

MEASURED DATA:

1. Modulate the transmitter with QPSK modulation, using pseudo random data.
Obtain image on spectrum analyzer.

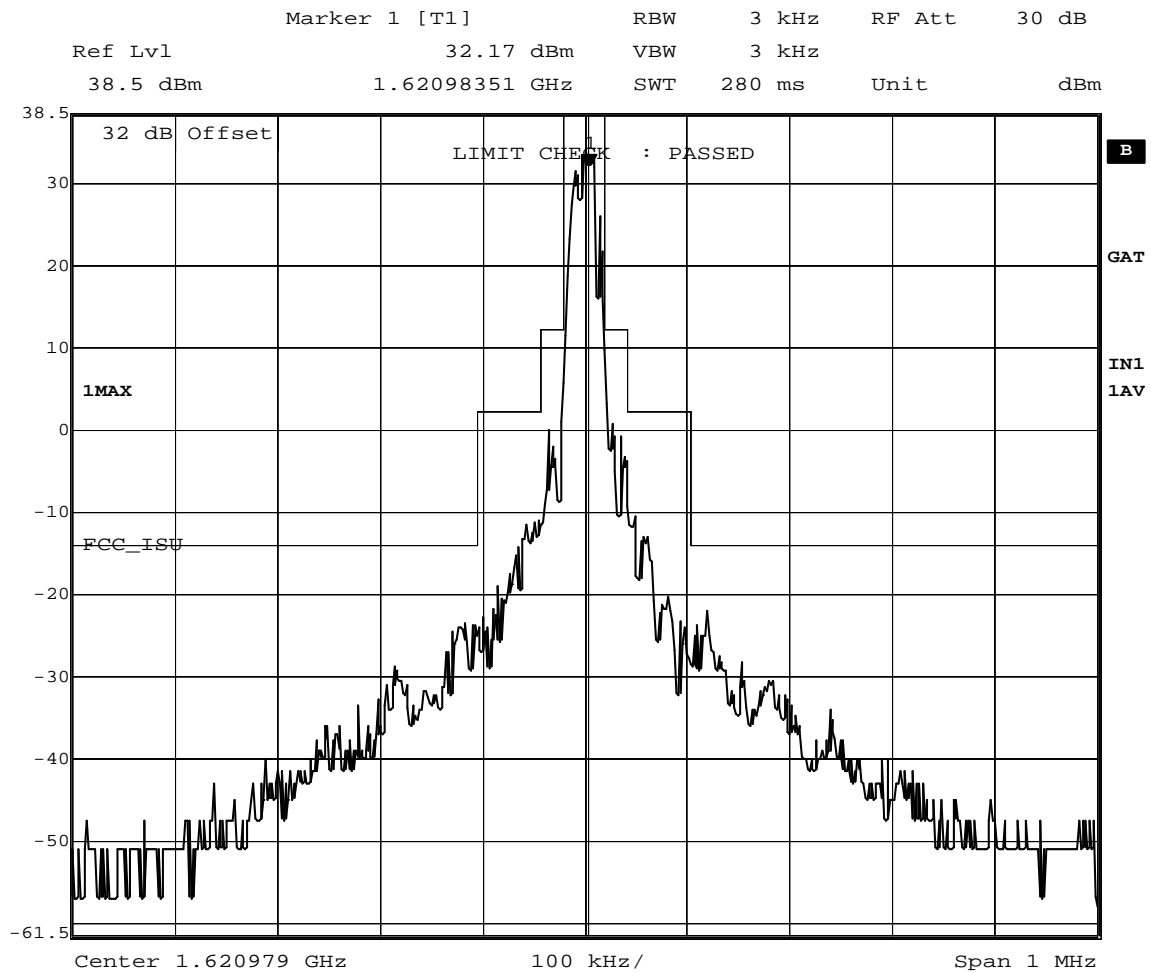

Date: 21.MAR.2002 11:33:15

COMMENTS:

A 3 kHz resolution bandwidth was used instead of the 4 kHz specified in 47 CFR 25.202.
A correction factor was included in the limit for the bandwidth difference.

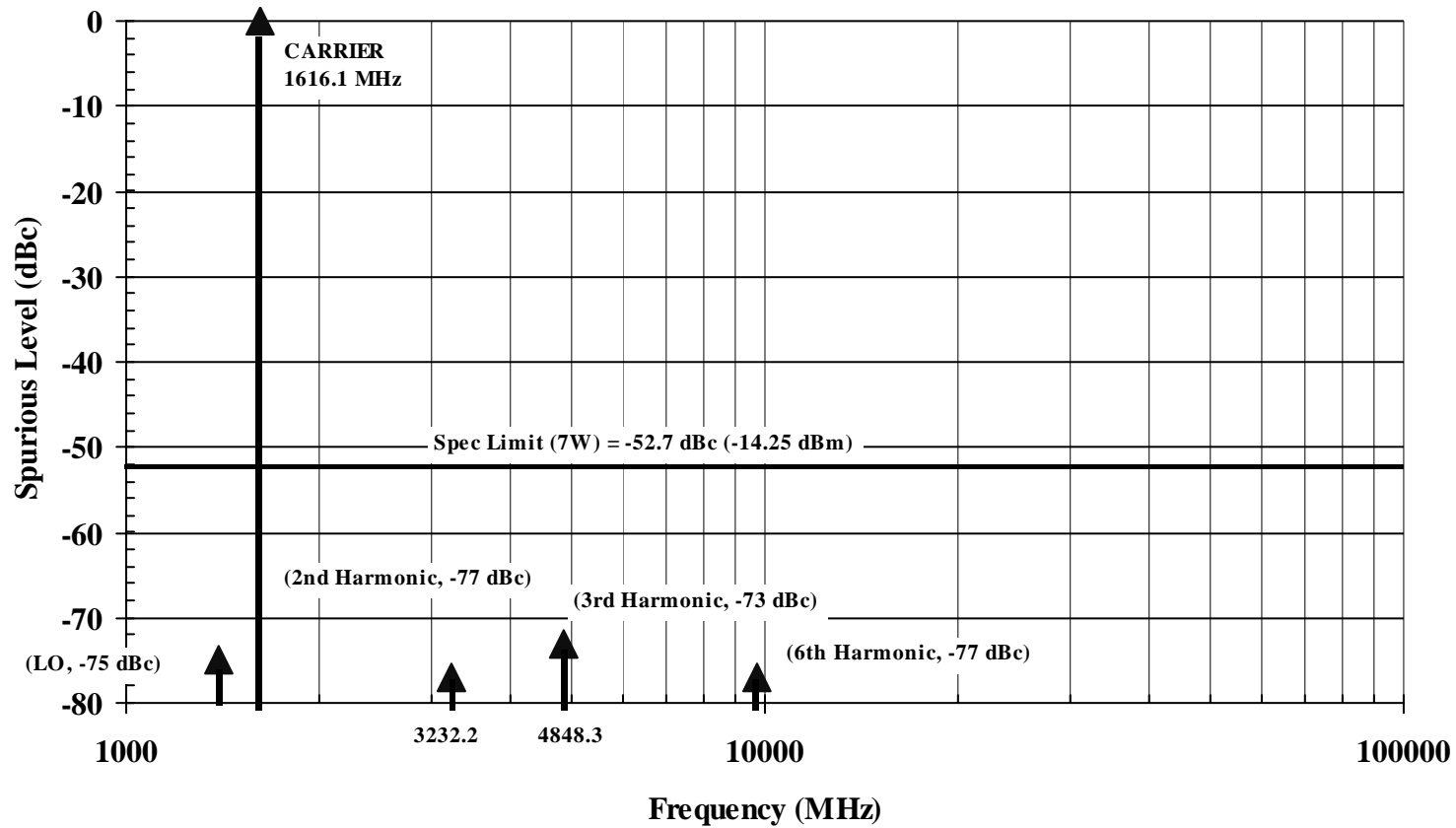

TRANSMITTER CONDUCTED EMISSIONS, CHANNEL #3

Carrier Power: 7 W max (+38.45 dBm), .645 W average (+28 dBm)

Carrier Frequency: 1616 to 1626.5 MHz (240 Channels)

Channels Tested: Channels #3, #120, and #238

*All other emissions greater than 20 dB below the spec were not reported

*No observable signals in GNSS band (1559-1605 MHz)

*Spectrum search performed from 30 MHz to 16.3 GHz (10X Carrier Frequency)

GDDS EMC Group
3/29/02

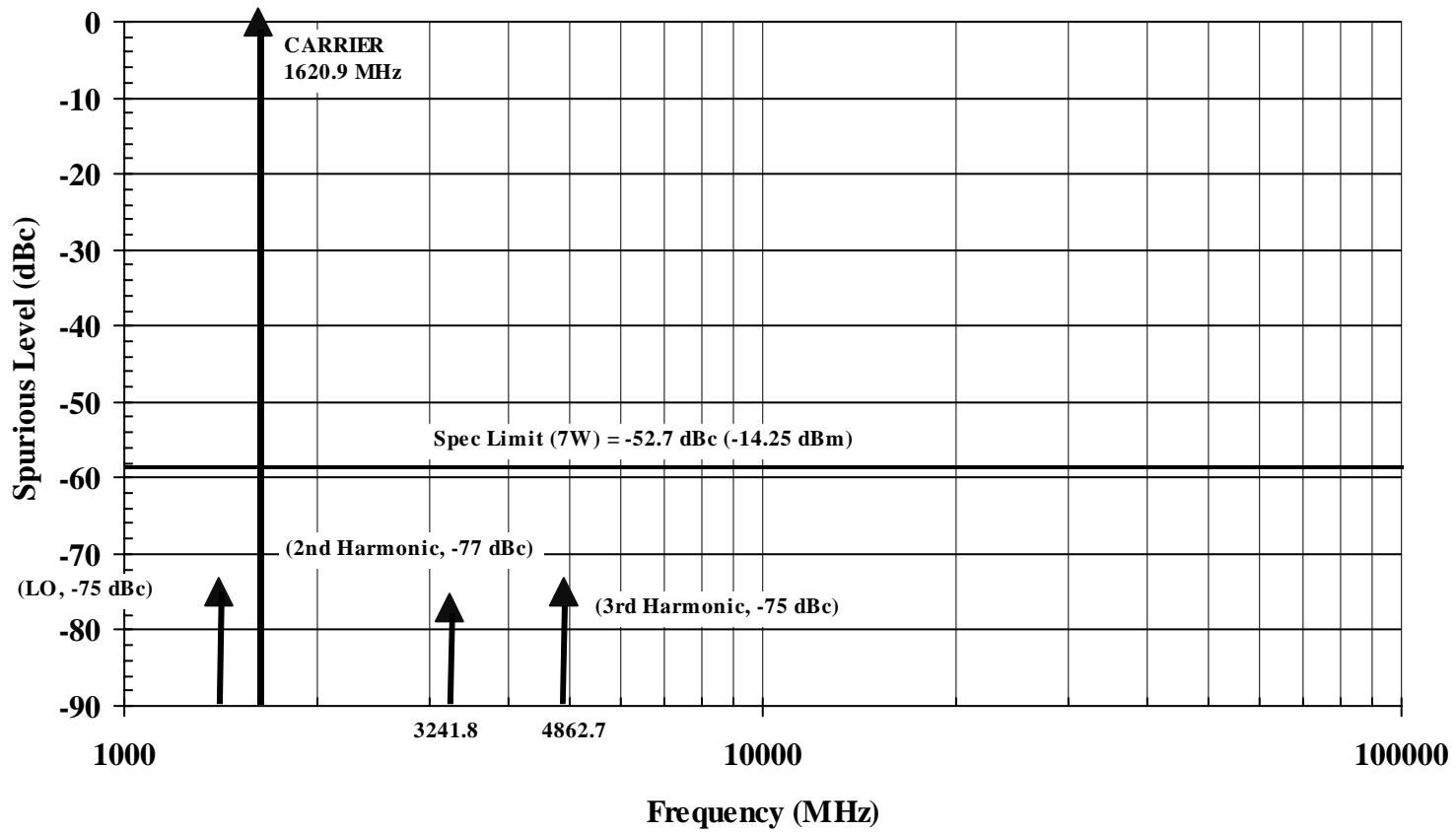

TRANSMITTER CONDUCTED EMISSIONS, CHANNEL #120

Carrier Power: 7 W max (+38.45 dBm), .645 W average (+28 dBm)

Carrier Frequency: 1616 to 1626.5 MHz (240 Channels)

Channels Tested: Channels #3, #120, and #238

*All other emissions greater than 20 dB below the spec were not reported

*No observable signals in GNSS band (1559-1605 MHz)

*Spectrum search performed from 30 MHz to 16.3 GHz (10X Carrier Frequency)

GDDS EMC Group
3/29/02

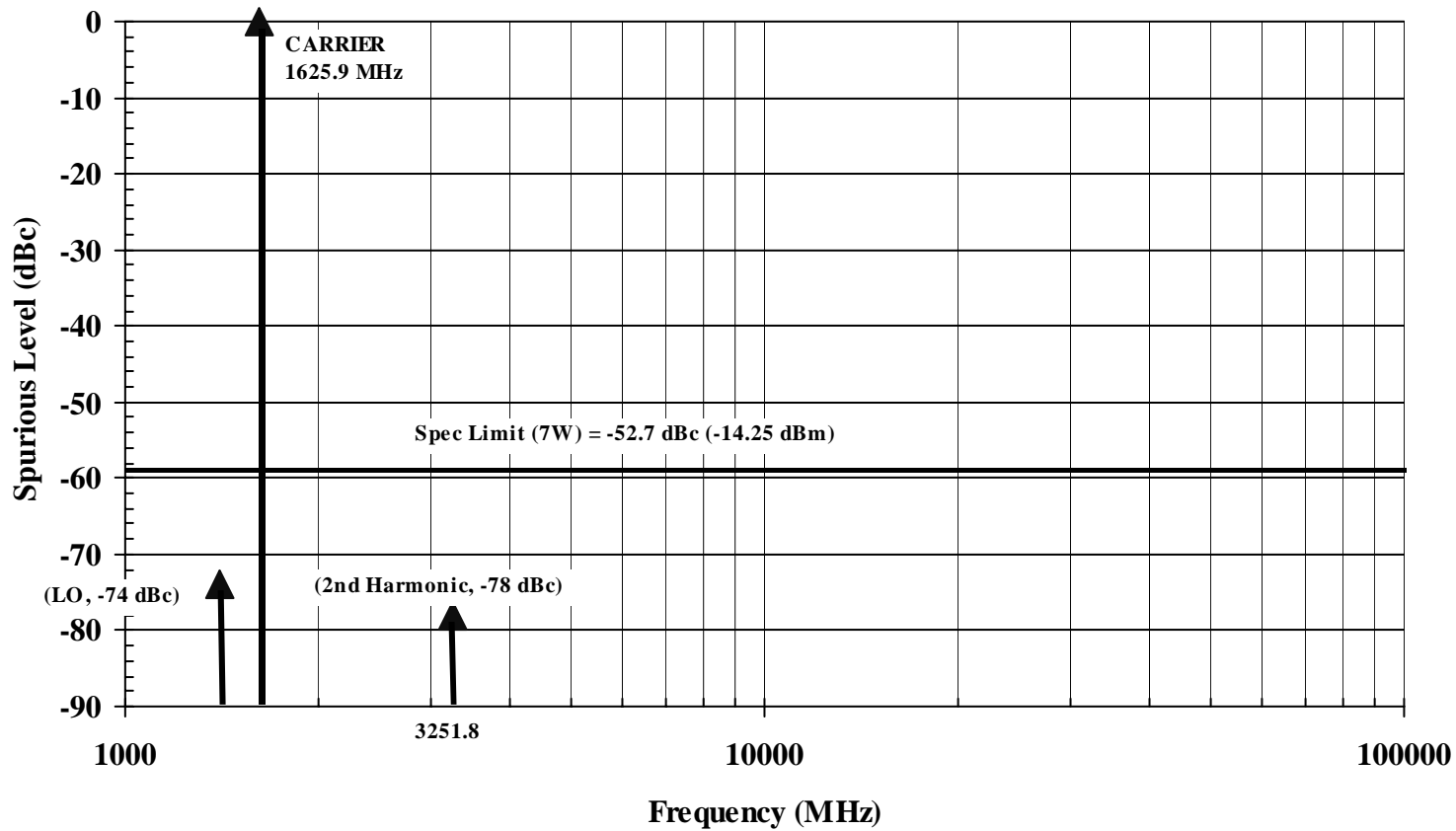

TRANSMITTER CONDUCTED EMISSIONS, CHANNEL #238

Carrier Power: 7 W max (+38.45 dBm), .645 W average (+28 dBm)

Carrier Frequency: 1616 to 1626.5 MHz (240 Channels)

Channels Tested: Channels #3, #120, and #238

*All other emissions greater than 20 dB below the spec were not reported

*No observable signals in GNSS band (1559-1605 MHz)

*Spectrum search performed from 30 MHz to 16.3 GHz (10X Carrier Frequency)

GDDS EMC Group
3/29/02

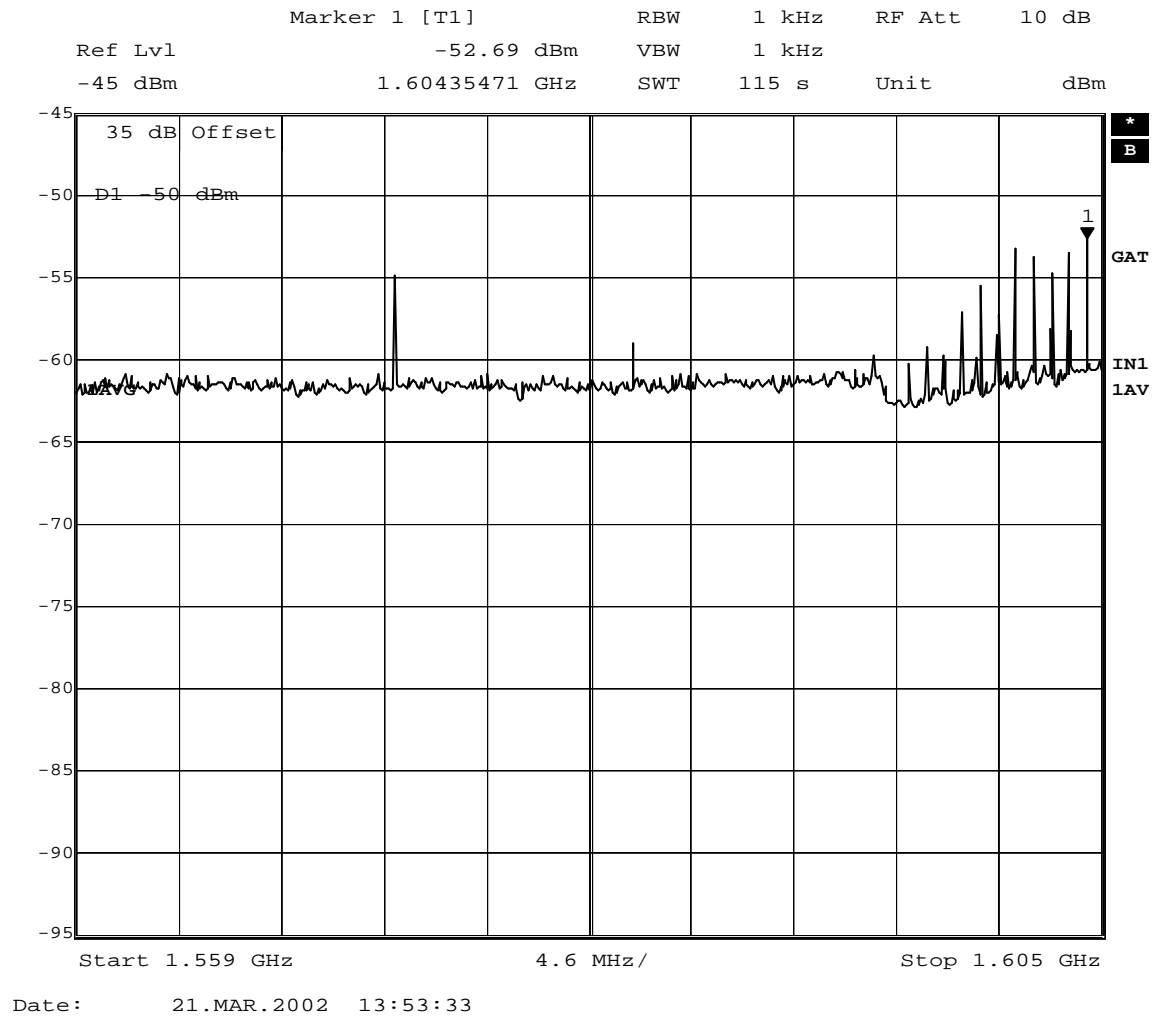

GPS/GLONASS NARROWBAND EMISSION SCANS

Channels Tested: Channels #3, #120, and #238

*Data measured in accordance with Part 25.200 (c)

*The data was similar for all three channels and only the worst case scans are included in this report

*A 1 kHz resolution bandwidth was used for the narrowband measurement instead of 700 Hz

GDDS EMC Group
3/29/02

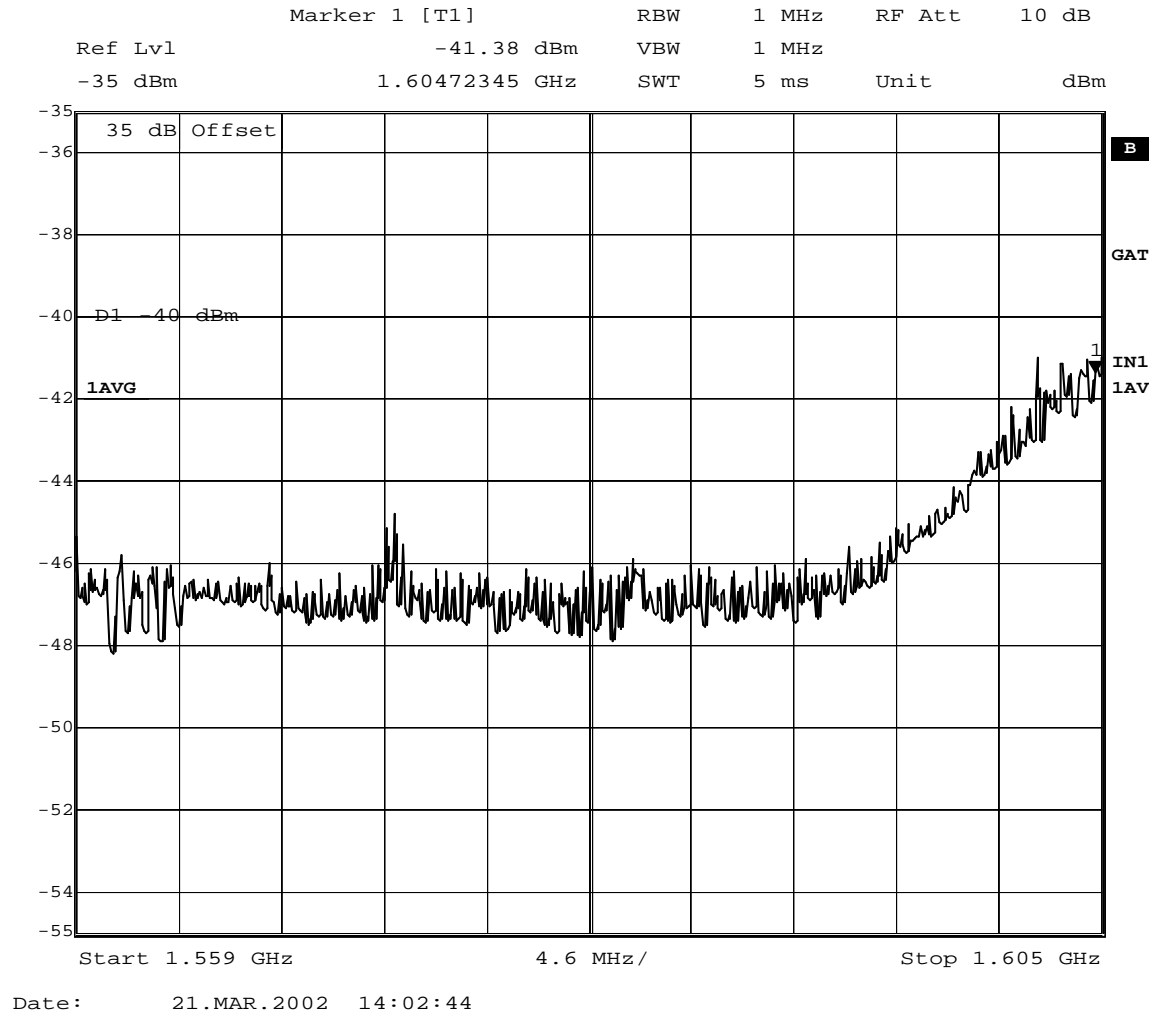

GPS/GLONASS WIDEBAND EMISSION SCANS

Channels Tested: Channels #3, #120, and #238

*Data measured in accordance with Part 25.200 (c)

*The data was similar for all three channels and only the worst case scans are included in this report

GDDS EMC Group
 3/29/02

Appendix C

Frequency Stability Measurements

Frequency Shift vs. Temperature

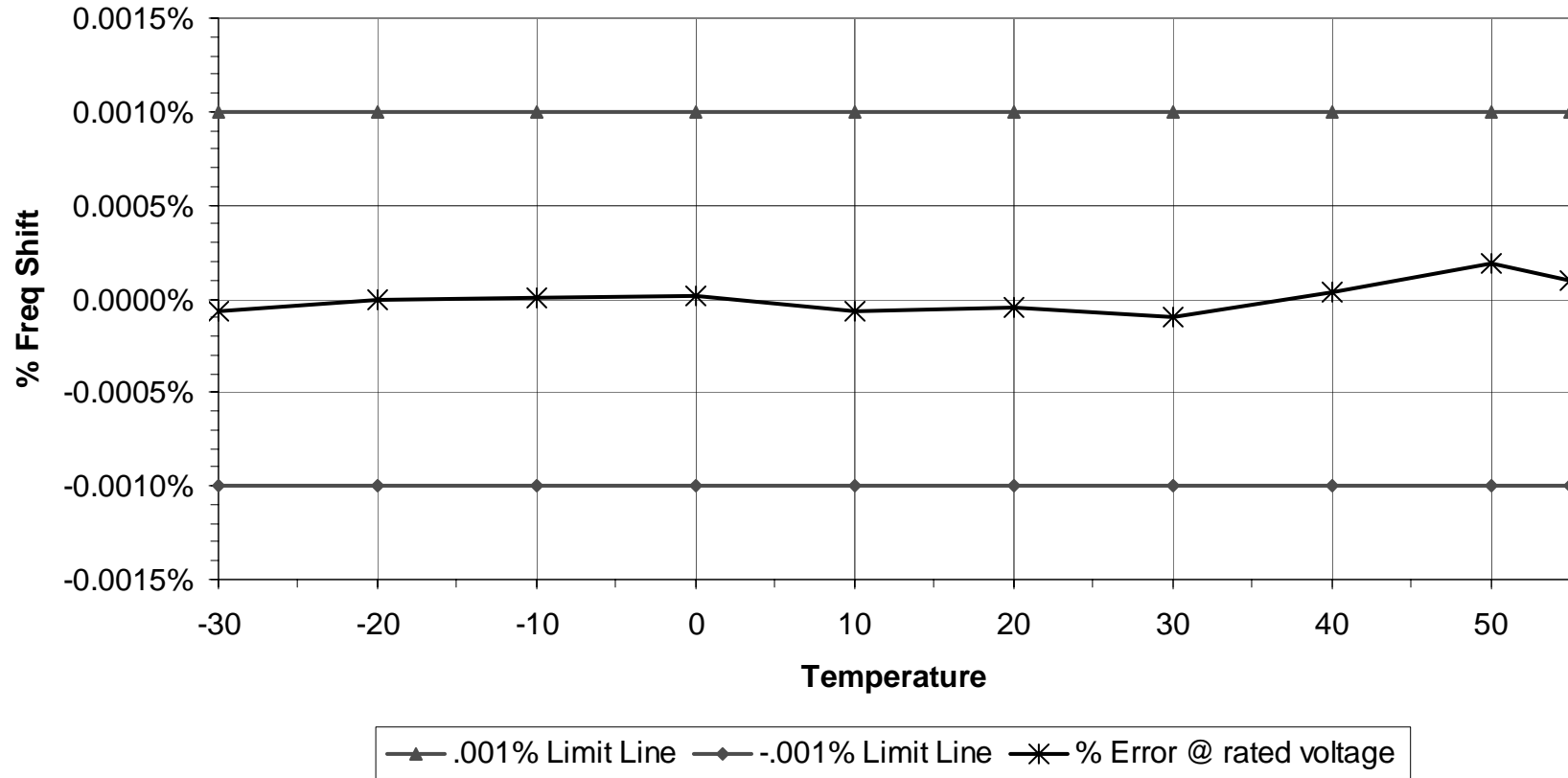

TRANSMITTER FREQUENCY STABILITY VS. TEMPERATURE

Frequency Shift Versus Voltage @ 20 °C

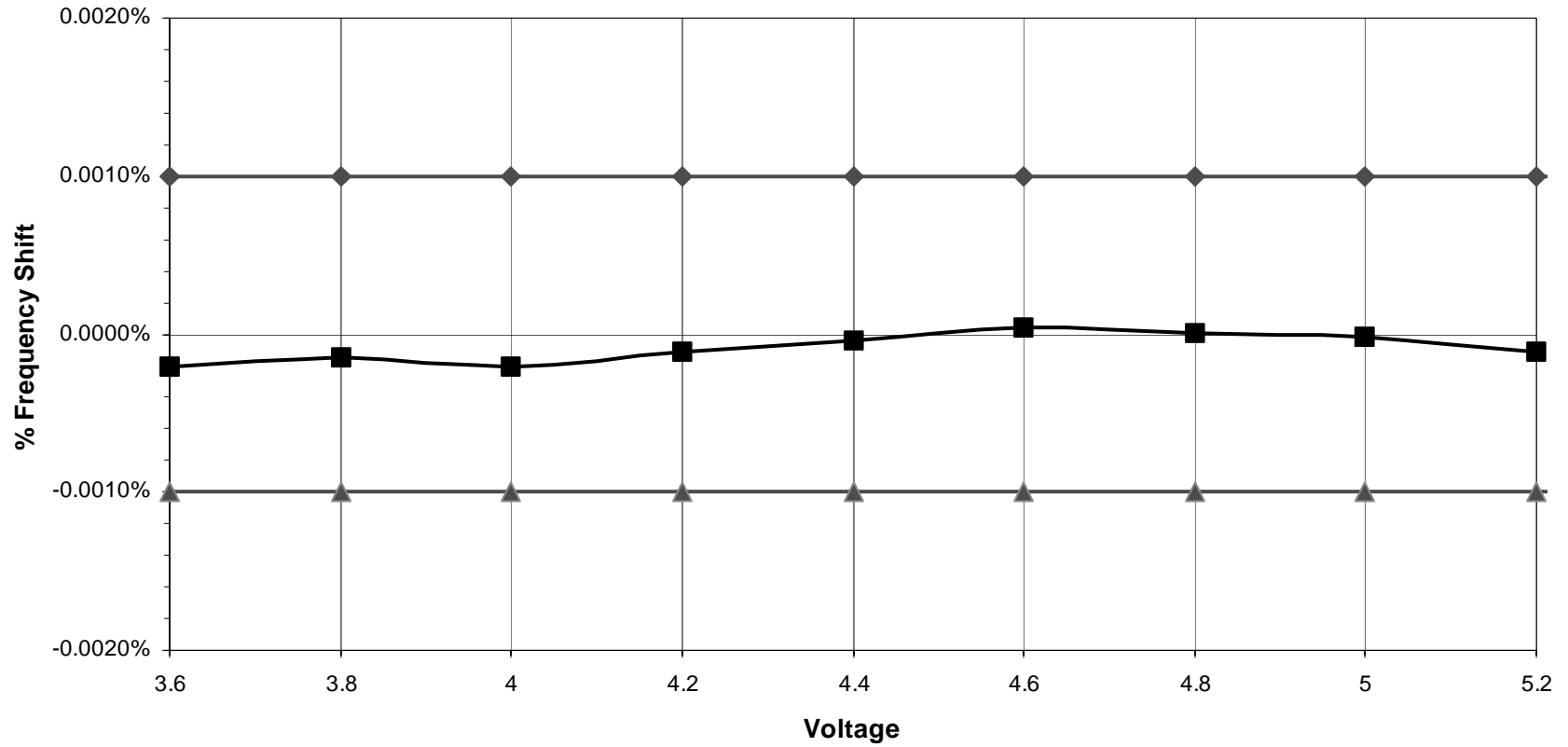

TRANSMITTER FREQUENCY STABILITY VS. SUPPLY VOLTAGE

Appendix D
CTR 41 Measurement Data
(For Information Only)

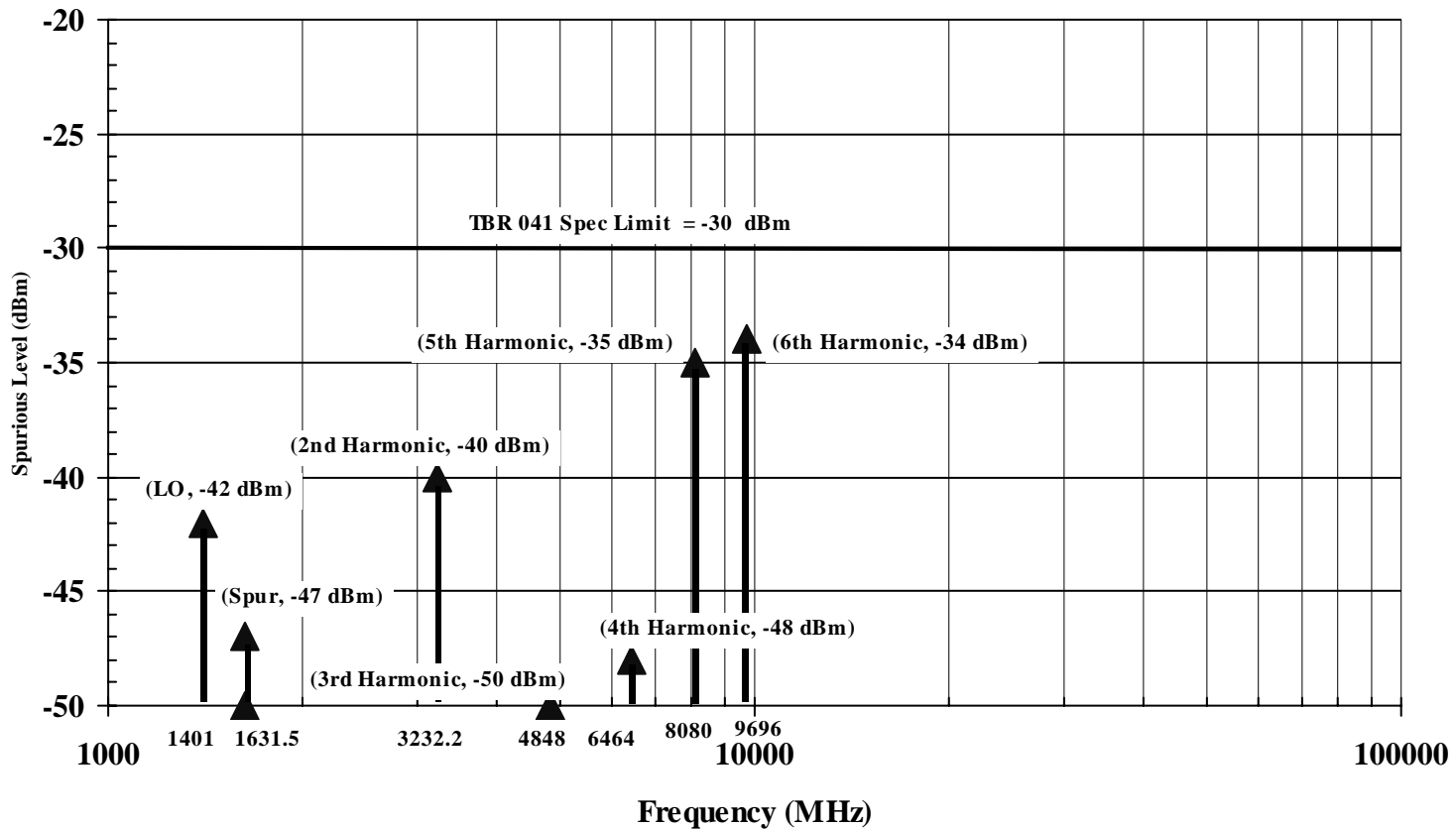

CTR 41 OUT OF BAND CONDUCTED EMISSIONS, CHANNEL #3

Carrier Power: 7 W max (+38.45 dBm), .645 W average (+28 dBm)

Carrier Frequency: 1616 to 1626 MHz (240 Channels)

Channels Tested: #3 and #238

*All other emissions greater than 20 dB below the spec were not reported

*Spectrum search performed from 100 kHz to 12.75 GHz

GDDS EMC Group

03/29/02

Exhibit 6

FCC ID: IHDT6NJ1

3/29/02

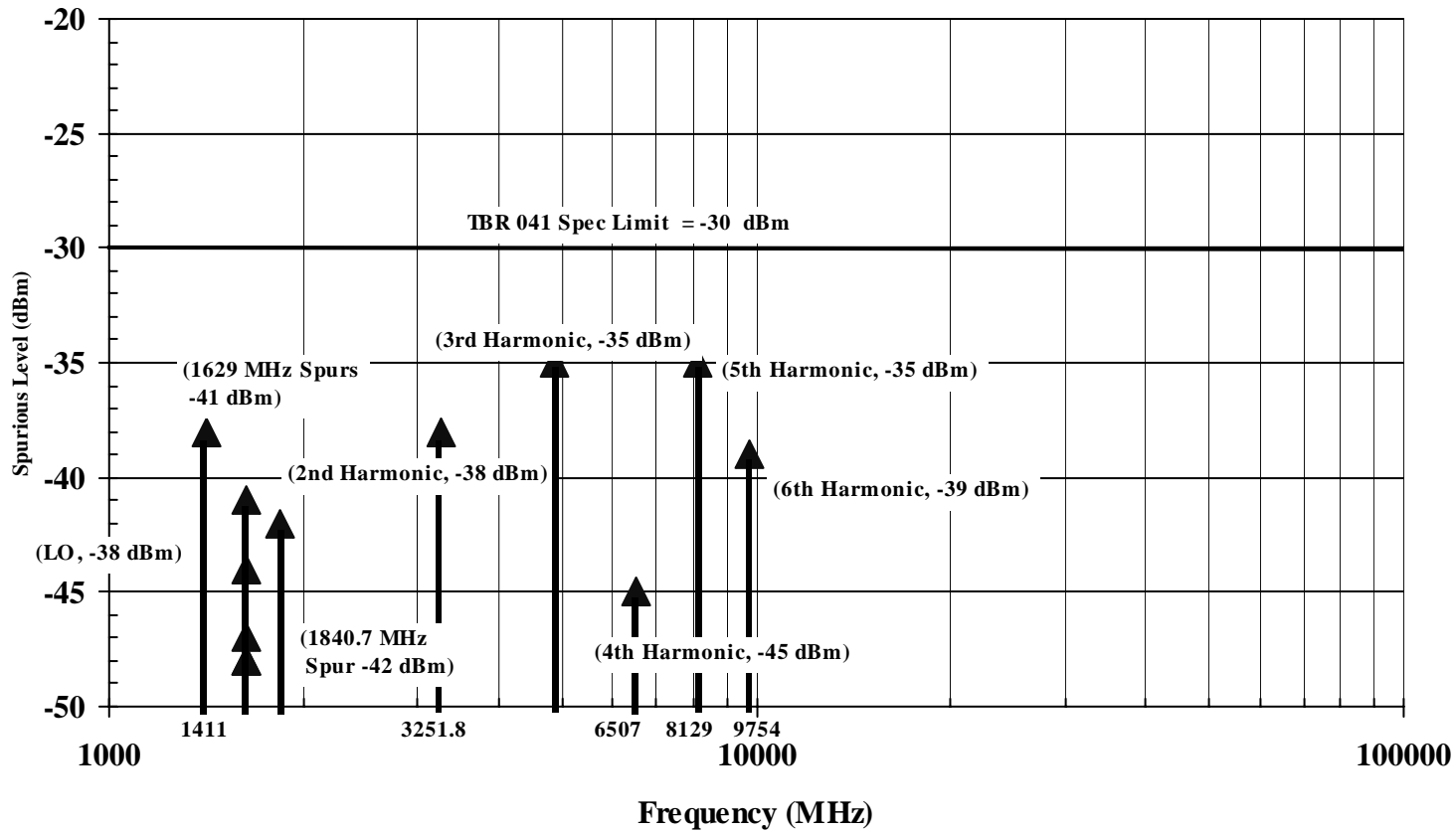

CTR 41 OUT OF BAND CONDUCTED EMISSIONS, CHANNEL #238

Carrier Power: 7 W max (+38.45 dBm), .645 W average (+28 dBm)

Carrier Frequency: 1616 to 1626 MHz (240 Channels)

Channels Tested: #3 and #238

*Emissions greater than 20 dB below the spec were not reported

*Spectrum search performed from 100 kHz to 12.75 GHz

GDDS EMC Group
03/29/02

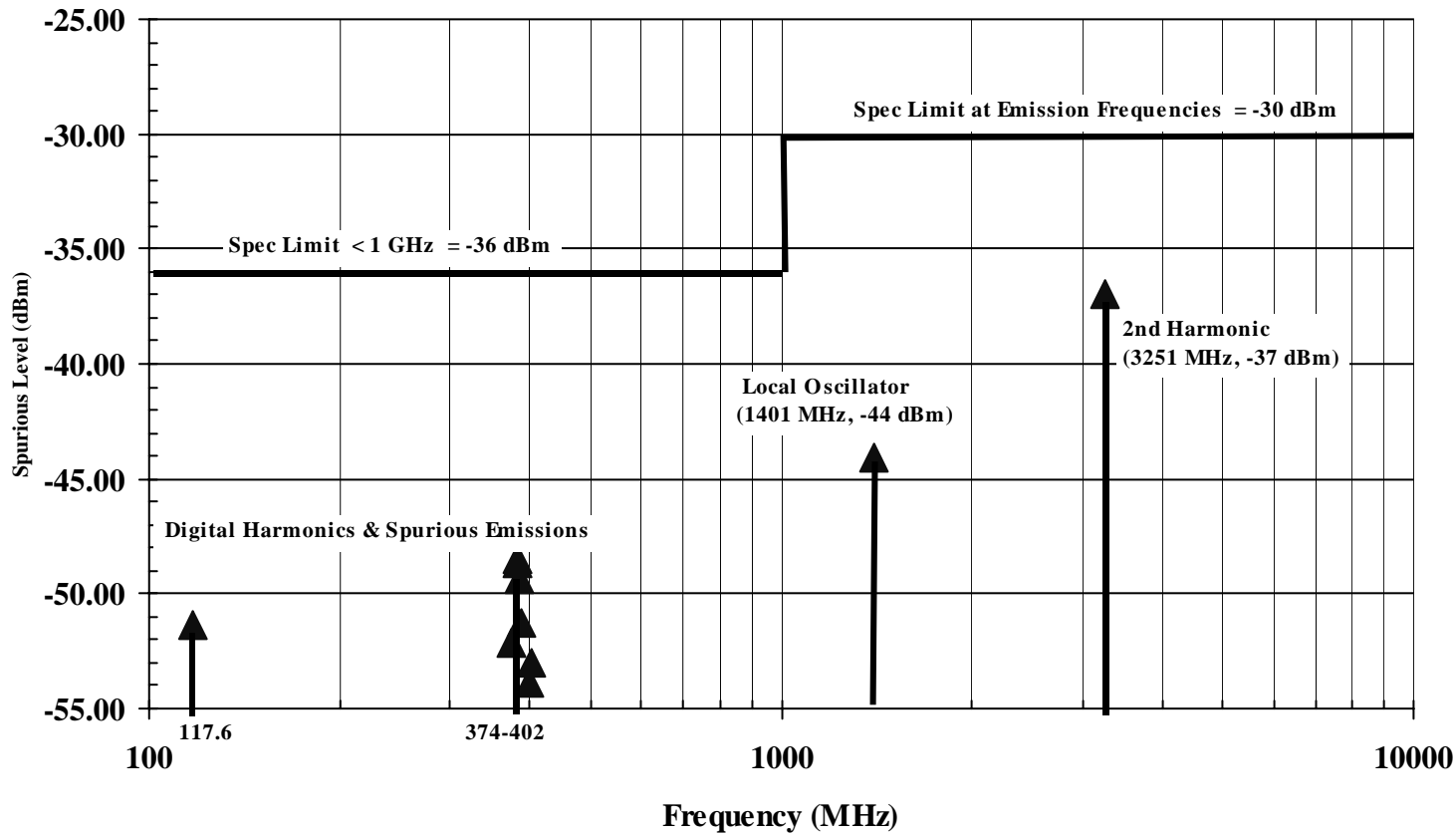

RADIATED EMISSIONS, CABINET, ANTENNA PORT TERMINATED

Carrier Power: 7 W max (+38.45 dBm), .645 W average (+28 dBm)

Carrier Frequency: 1616 to 1626 MHz (240 Channels)

Channels Tested: #3 and #238 (Graph represents worst case emissions)

*All other emissions greater than 20 dB below the spec were not reported

*Spectrum search performed from 30 MHz to 4 GHz

GDDS EMC Group
03/29/02

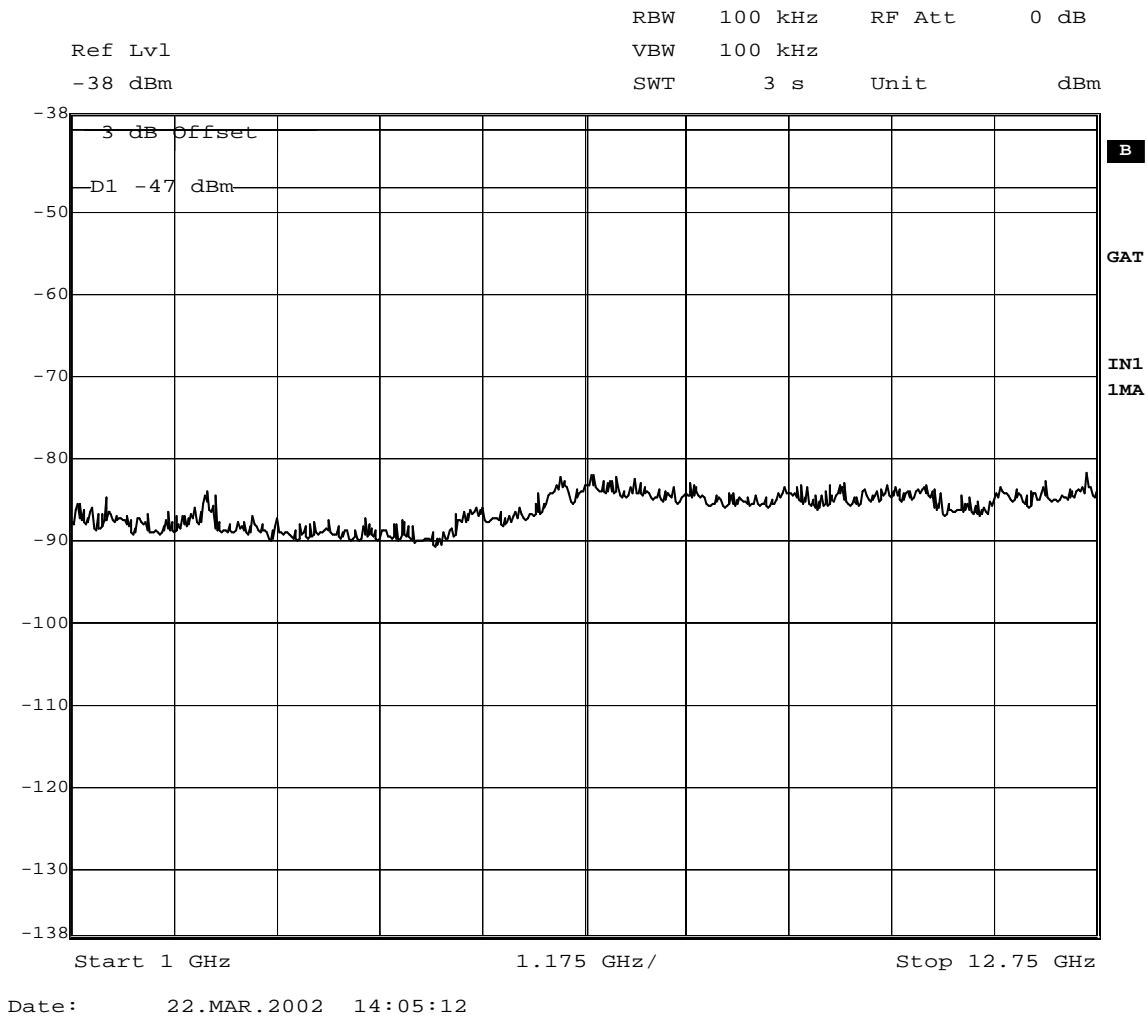

CTR 41 CONDUCTED EMISSIONS, CARRIER-OFF (3 of 3)

- *Phone placed in Ring Alert Monitor (Receive Only) Mode
- *Spectrum search performed from 100 kHz to 12.75 GHz
- *Frequency coverage presented in three segment scans

GDDS EMC Group
 3/29/02

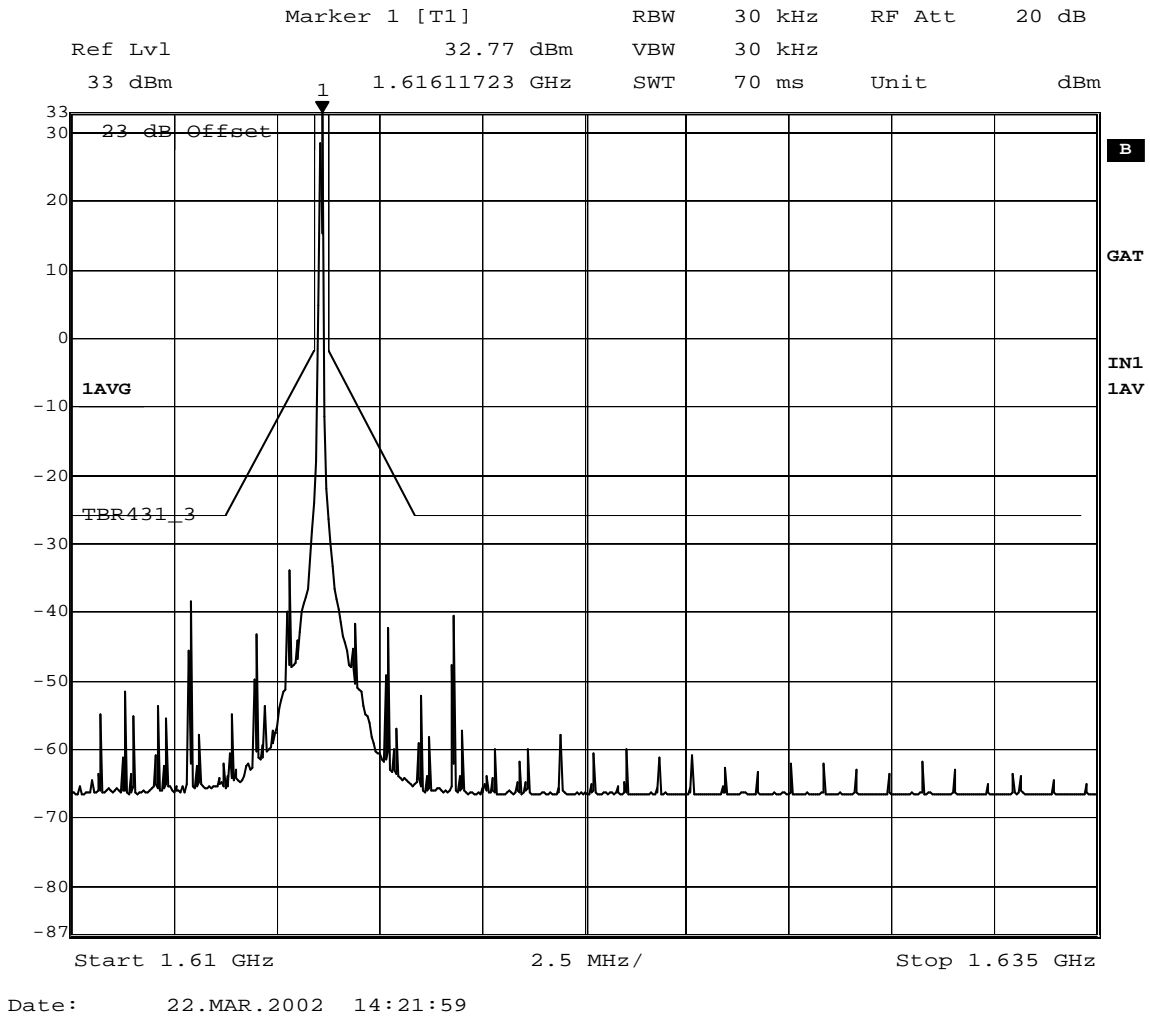

CTR 41 IN-BAND CONDUCTED EMISSIONS

Carrier Power: 7 W max (+38.45 dBm), .645 W average (+28 dBm)
Carrier Frequency: 1616 to 1626.5 MHz (240 Channels)
Channel Tested: #3

GDDS EMC Group
03/29/02

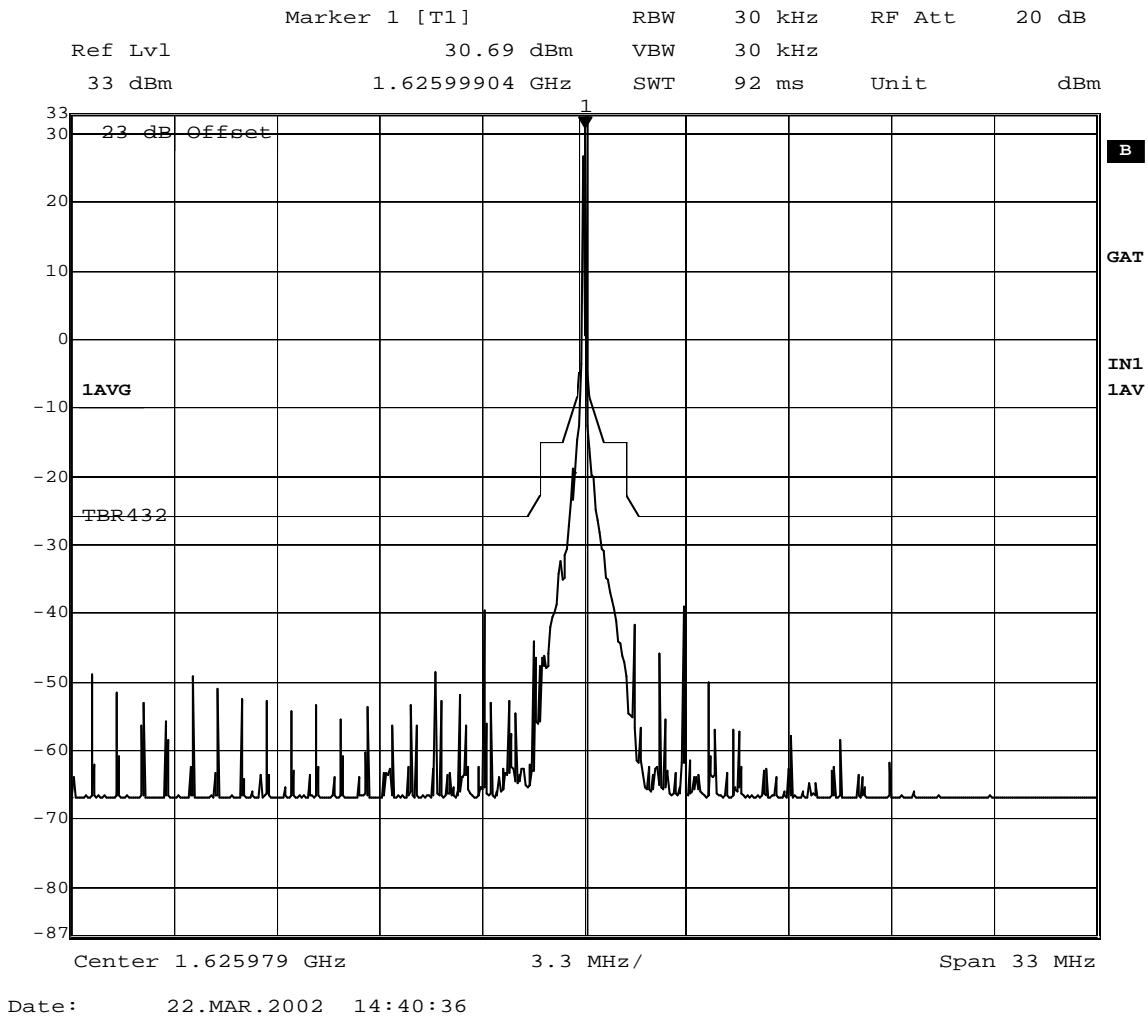

CTR 41 IN-BAND CONDUCTED EMISSIONS

Carrier Power: 7 W max (+38.45 dBm), .645 W average (+28 dBm)
 Carrier Frequency: 1616 to 1626.5 MHz (240 Channels)
 Channel Tested: #238

GDDS EMC Group
 03/29/02

**General Dynamics Decision Systems
Test Data Sheet**

CTR 41			EIRP Density Measurement	Comments:	
Equip.	Iridium Subscriber Unit		Test Date:		3/27/2002
Mode:	Traffic Channel		Test Technician:		G. Estrella
Model#:	Sebring 9522		Measurement Distance (m)		Conducted
Serial #:	4D#2		Equipment Class		N/A
		EIRP Density			
Frequency (MHz)	EIRP Density (dBm/4kHz)	mean limit (dBm/4kHz)			
1616.021	+23.7	+27		Channel # 01	
1616.104	+21.6	"		Channel # 03	
1616.188	+23.4	"		Channel # 05	
1616.271	+24.0	"		Channel # 07	
1620.979	+24.7	"		Channel # 120	
1621.063	+21.4	"		Channel # 122	
1621.146	+22.2	"		Channel # 124	
1621.229	+21.8	"		Channel # 126	
1625.646	+23.4	"		Channel # 232	
1625.729	+23.2	"		Channel # 234	
1625.813	+23.3	"		Channel # 236	
1625.900	+22.4	+27		Channel # 238	